

# MK II OPERATOR'S MANUAL

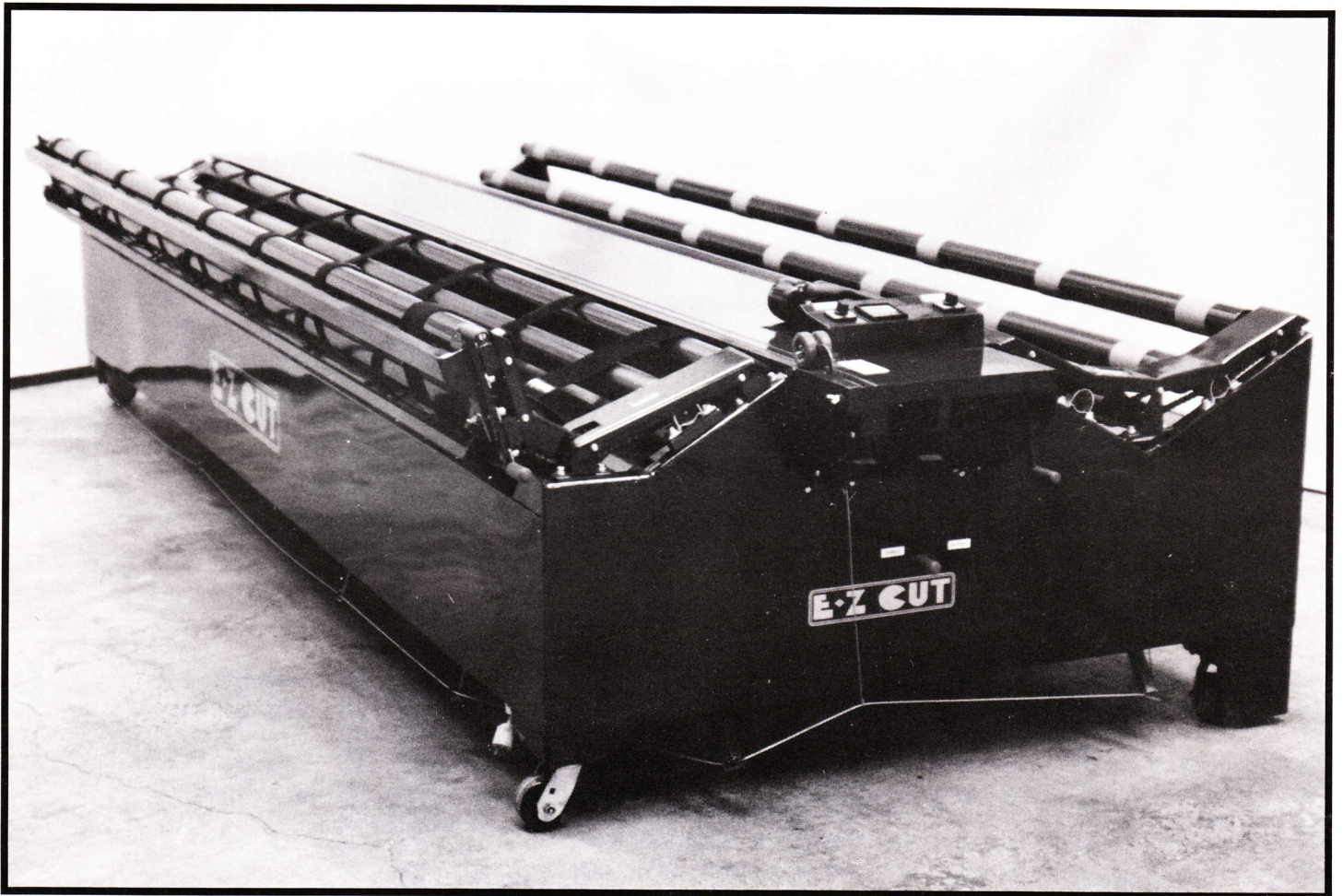

**E-Z CUT INC.**

# SAFETY RULES

## GENERAL

1. Read the Operator's Manual carefully to ensure that you are familiar with the controls and the proper step by step operation of the machine.
2. Never allow children to operate the machine and only those people who fully understand the machine's proper procedures should use it.
3. Keep the area of operation clear of all persons and potential hazards.
4. Should you have any problems with the operation of the machine, consult the "Troubleshooting and Maintenance" sections at the back of the manual.
5. If help is needed or if any of these procedures are unclear, please contact an E-Z CUT representative immediately.

## OPERATING PROCEDURES

The following is the cutting machine's general operating procedures and parts description. The steps in this section are set up for a normal sequence of operations. The arrangement is intended primarily to acquaint you with the fundamental operating procedures to ensure the safe and efficient operation of your cutting machine. Take your time, be patient, and enjoy the benefits of this machine for many years to come.

**E-Z CUT INC.**

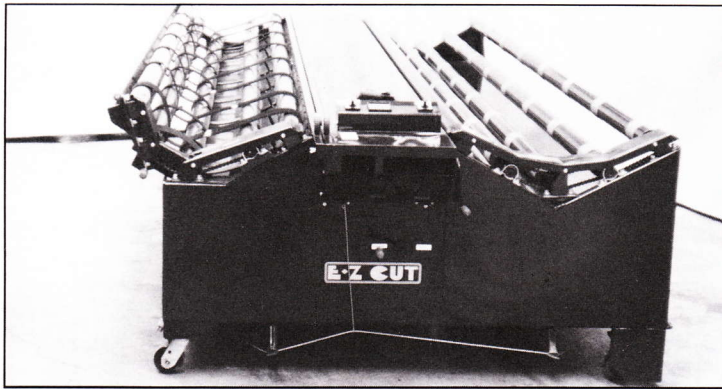

## The Machine's Arrival

Once the machine has arrived and the crating has been removed, give your machine a complete wiping and dusting to remove any pieces of wood or plastic that still might remain after uncrating. Once cleaned and positioned to where it will be operated from, release the machine down from its Levered Caster Wheels to prevent it from moving during the loading of rolls and actual operation.

# MAIN OPERATING FEATURES

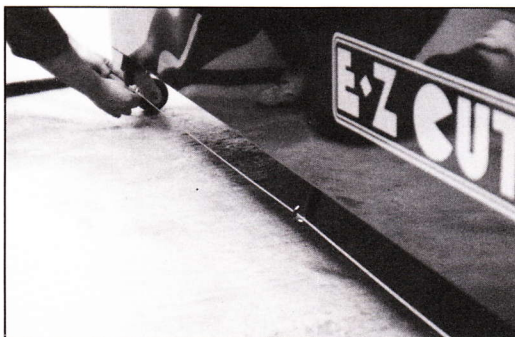
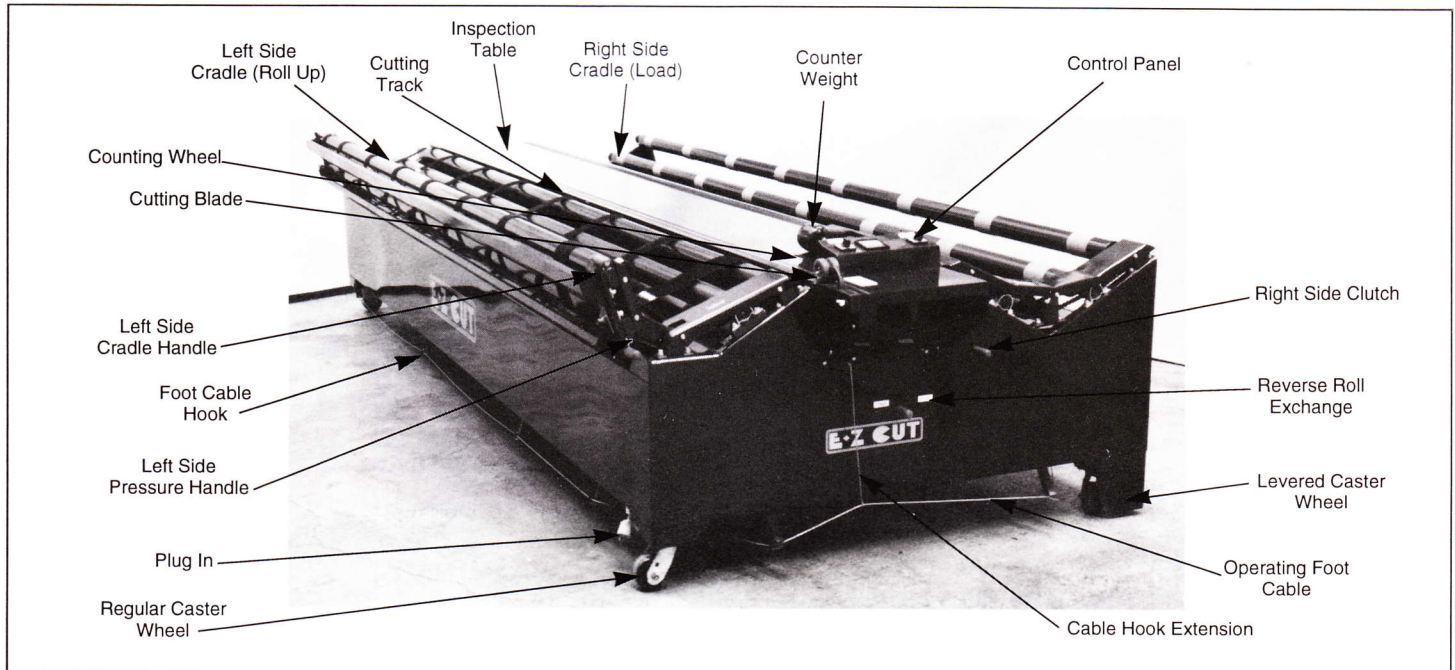

## Operating Foot Cables

Secure the Operating Foot Cable at the far end on both sides of the machine by removing the Eye Bolt Nut, sliding the Eye Bolt through the Bolt Hole, and refastening the Nut into place. Leave enough slack so as to properly secure the Foot Cable through the Foot Cable Hooks as well as the Cable Hook Extension in the front. Adjust the tension of the Cable by loosening or tightening the Eye Bolts and Nuts at the far end of the machine.

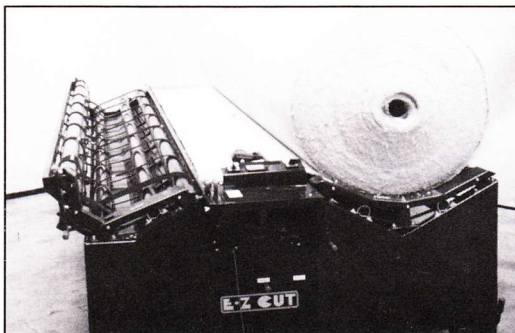

## Loading The Roll of Carpet

When loading a roll of carpet, you always load it onto the RIGHT SIDE Cradle and ensure that the feed is coming from the BOTTOM towards the Counter with the "Pile" facing UP. This provides an accurate measurement as the carpet backing passes over the Counting Wheel – NEVER MEASURE WITH THE "PILE" FACING DOWN AS YOU WILL GET INACCURATE MEASUREMENTS. As well, for best results, the roll should be rolled up fairly tight. To tighten a loose roll of carpet, turn the Rollers Switch in REVERSE, depress the Foot Cable, and allow the roll to rotate for a few turns until it tightens itself up.

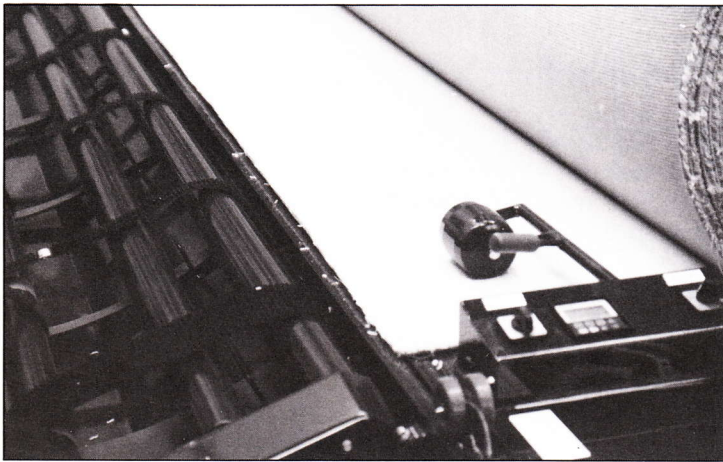

## Preparing to Measure

Advance the carpet across the Inspection Table by turning the Rollers Switch to FORWARD and depressing the Foot Cable. At the same time, lift the Counter Weight and guide the carpet under it to the Cutting Track. Stop the carpet at the edge of the Cutting Track and gently lower the Counter Weight down onto the carpet. The Cutting Track is your start and finish line when making cuts and the edge of the carpet should be parallel with it if the roll is cut square and is rolled up straight. If you have a roll that is not square or rolled up so it is coned or telescoped, then it will not line up parallel to the Cutting Track. In this case, advance the carpet so the short side is even with the Cutting Track and the long side is past it.

## Programming the Electronic Counter

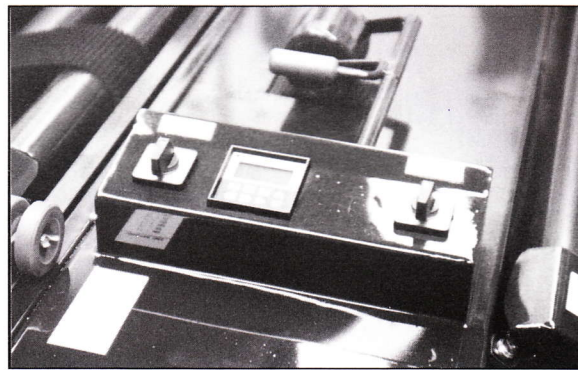

With the edge of the carpet lined up along the edge of the Cutting Track, you are now ready for the counting and roll up process to begin. To program your Counter to a desired length, please adhere to the following steps:

- 1) Press the “+” or “-” buttons until you arrive at the “P1” screen and then press the “RST CLR” button to clear the screen.
- 2) The Top Row will indicate the length of flooring that is actually being measured. The Bottom Row is where you can program a desired length to be measured.

NOTE: Due to the momentum of the carpet as it is being rolled up, a small amount (Approx. 2”) is also measured and recorded since the machine does not stop instantly once the programmed length is reached. Therefore, you may want to program the Counter for 2” less than the desired length to compensate for this extra amount.

Example:	Desired Length (Row 1)	= 20.00 Feet
	Programmed Length (Row 2)	= 20.00 less 2”.
		= 20.00 - 0.16
		= 19.84

Therefore, the machine will stop once the Counter reaches 19.84 and the momentum of the roll should carry it forward to 20.00 Feet.

If this step is too confusing, then just disregard the compensated amount and pre-set the Counter for your desired length. Once the machine has stopped (approx. 2” past your desired amount), you can turn the Rollers Switch to REVERSE and tap the Foot Cable to bring the carpet back to the correct amount.

- 3) Press the “SEL” button and you will notice that the first “0” on the Bottom Row will begin to flash.
- 4) Press the “+” or “-” buttons until you reach the desired value at each digit position. Once you have reached the desired value at a specific position, just press the “SEL” button and you will be advanced to the next digit position.
- 5) When you have reached your desired values at each position via the “SEL” and “+/-” buttons, press the “ENT” button to lock in this desired length. If you wish to make any changes, just press the “SEL” button and follow Step #4 again.

NOTE: Be sure to follow these steps for each and every measurement and cut.

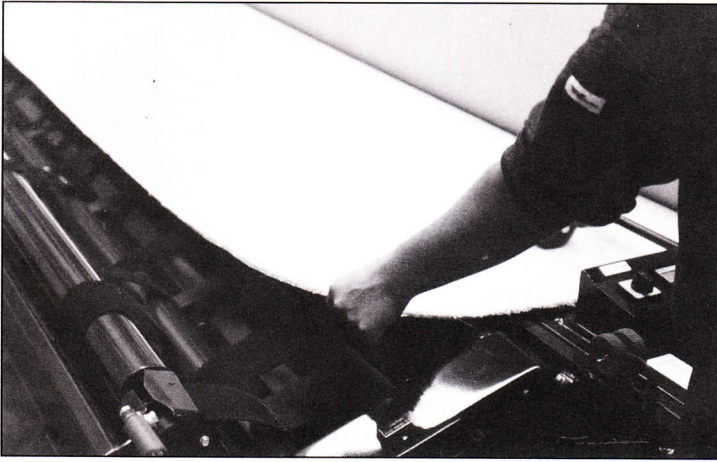

### Starting the Roll Up Process

With the Rollers Switch in FORWARD, depress the Foot Cable and gently pull the edge of the carpet across with your left hand for the first foot or so.

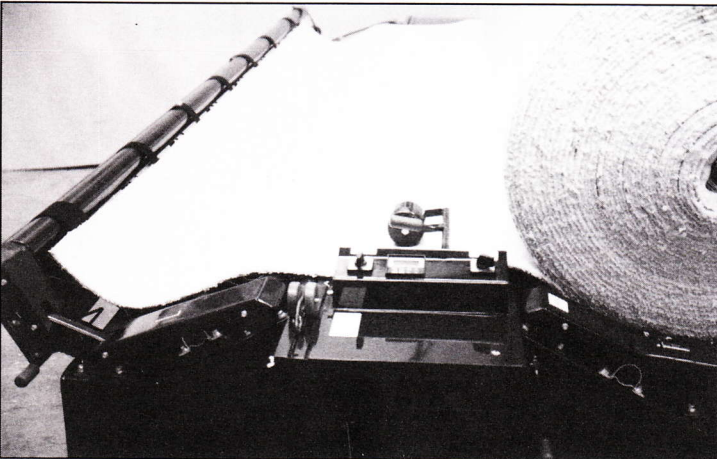

### Guiding the Flooring

Guide the flooring so that it is even with the center of the last (outside) roller on the Left Side Cradle and stop the flow at this point. Should you require one, you can place a core on top of the carpet in the cradle at this time.

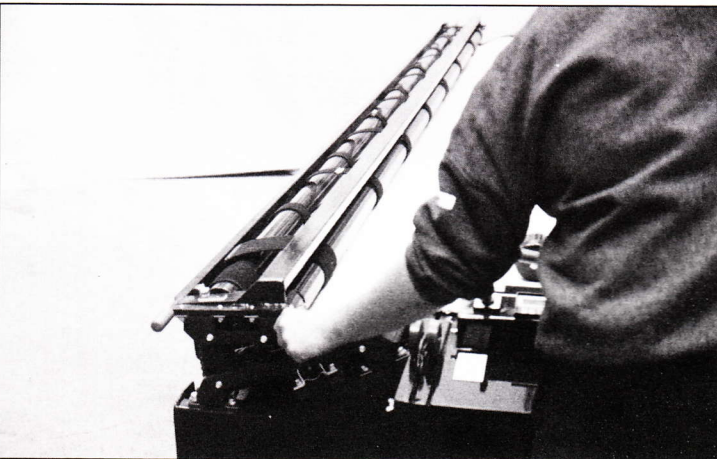

### Rolling Up the Carpet

To get the roll started, curl up the Left Side Cradle by pulling the Handle towards you until the Cradle has fully enclosed the carpet. Step/Tap on the Foot Cable while keeping the Cradle curled up into place so as to get the roll up started. You do not have to apply an extreme amount of pressure on the curl up but just enough to prevent the carpet from popping out of the Cradle.

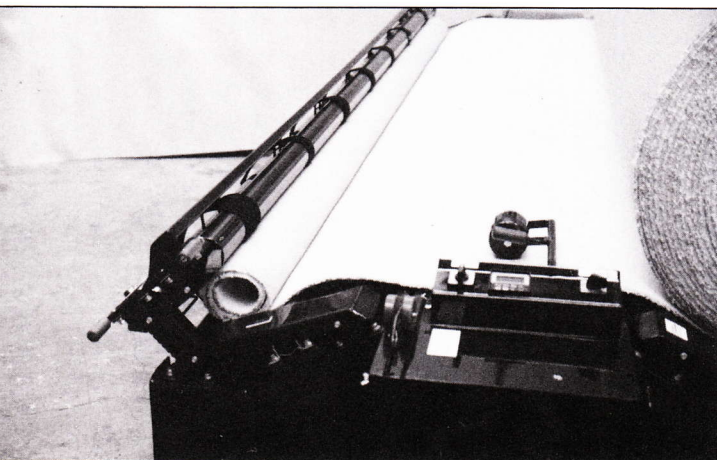

### Continuing the Roll Up

Once you have the roll up started with a couple of turns, you can slowly release the Handle and continue the roll up by stepping on the Foot Cable. You will notice that the Left Side Cradle is Spring Loaded and will apply enough pressure to keep the roll up fairly tight.

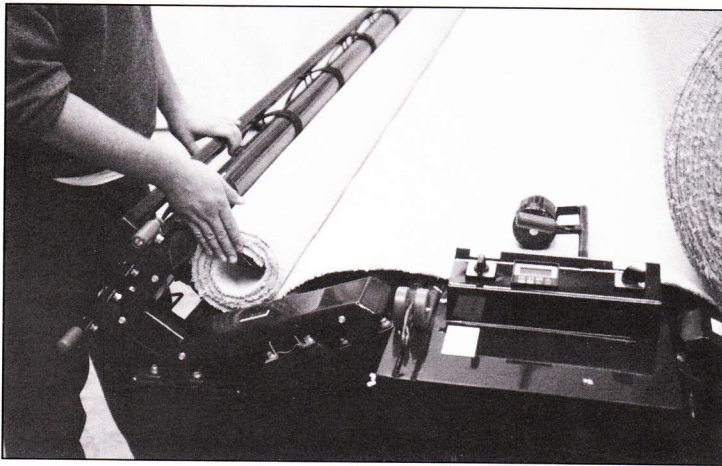

## Rolling Up the Carpet Straight

Contrary to what you may have been told, no cutting machine can square a roll of carpet. The only way to be sure that your carpet is going to be cut square is to ensure that it is rolled up straight and flush. To prevent coning or telescoping, move to the Left Hand Side of the machine once you've got the roll up started. By adjusting the carpet by hand as it rolls up (just like you would if you were rolling it up on the floor), you can eliminate any serious coning. If the carpet is rolled up fairly straight and not coned, then your cut will be straight and square.

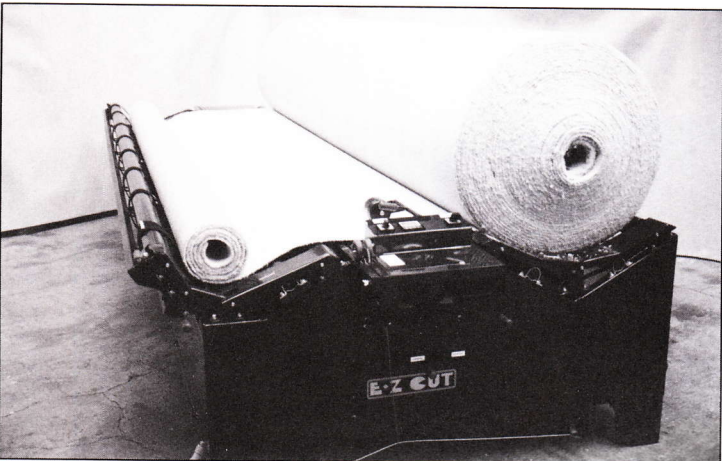

## Prior to Cutting

Once the machine has reached the desired length you have it programmed for, it will stop automatically. As mentioned earlier in the "Programming the Counter" section, you can make any adjustments to the measurement at this point if you wish.

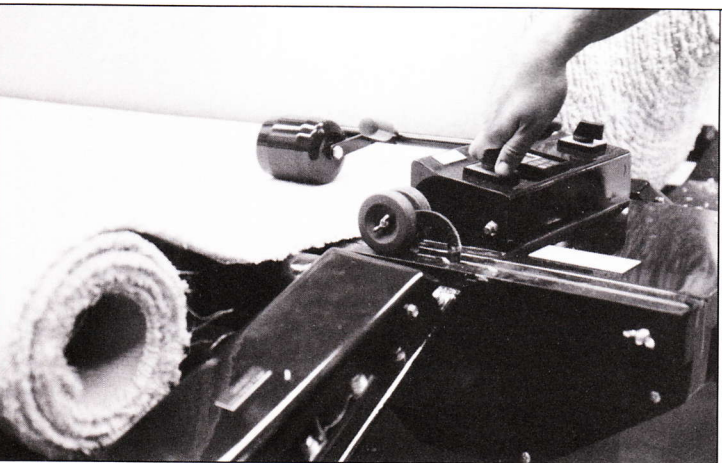

## Cutting the Carpet

To prevent accidental movement of the carpet during the cutting process, turn the Rollers Switch to the STOP position (between FORWARD and REVERSE). To cut the flooring, turn the Cutting Blade Switch in FORWARD and hold in place until the cut is complete. Once finished, turn the Cutting Blade Switch in REVERSE to return it to the front of the machine for the next cut.



## Wrapping the Rolls

To wrap up the cut piece, shift the Right Side Clutch Handle to the UP position so as to lock off the Right Side Cradle. Turn the Rollers Switch to FORWARD and position yourself along the Left Side of the machine. Place the stretchfilm under the edge of the carpet, step on the Foot Cable, and allow the stretchfilm to wrap itself around the cut piece. Repeat this step at the far end of the roll as well. As for the balance roll, re-engage the Right Side Cradle by shifting the Right Side Clutch Handle to the DOWN position. Turn the Rollers Switch to REVERSE and repeat the same steps as on the cut piece.

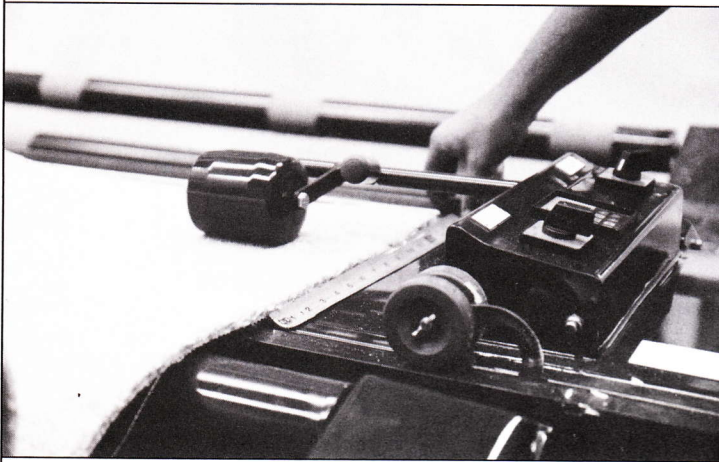

## Measuring Full/Partial Rolls

When just measuring full or partial rolls and not making any cuts, you have to remember one very important step. Since the Counter stops counting once the back edge of the carpet passes over the Counting Wheel, you have to take into account the small piece of carpet that doesn't get counted between the Counting Wheel and the Cutting Track. Therefore, prior to the back edge of the carpet passing over the Counting Wheel, measure the section of carpet from the back edge to the Cutting Track and add this amount to the reading on Row 1 of the Counter Screen. Use the Conversion Table.

Example: Row 1 Reading = 19.50  
= 19'6"

Section from Back Edge to Cutting Track = 1'2"

Therefore, Entire Piece = 19'6" + 1'2"  
= 20'8"

# REVERSE ROLLING CARPET "PILE" SIDE OUT

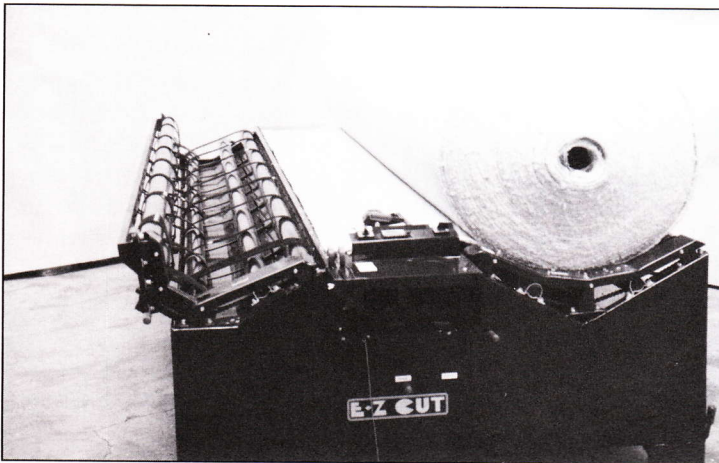

## Loading the Roll

As before, place the roll of carpet on the Right Side Cradle and ensure that the carpet feed is coming from the BOTTOM towards the Counter with the "Pile" side facing UP.

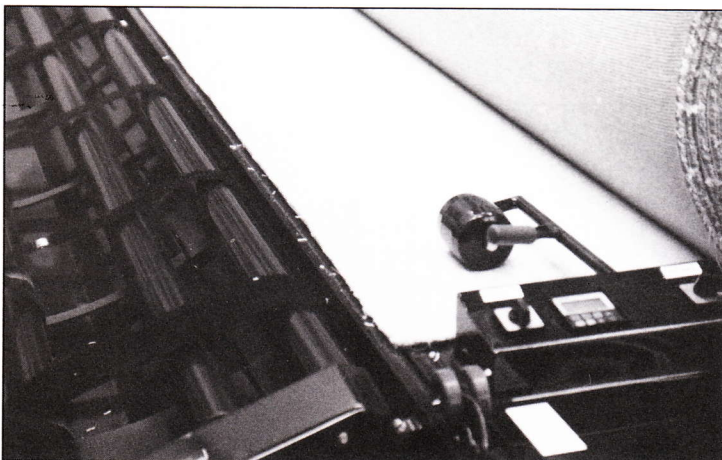

## Preparing to Measure

As before, advance the carpet across the Inspection Table, under the raised Counter Weight and stop it at the Cutting Track. Lower the Counter Weight down onto the carpet again so a correct measurement is always achieved.

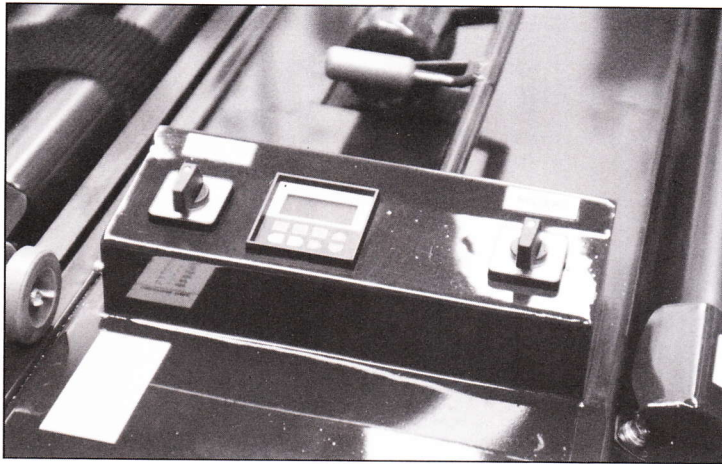

### Programming The Electronic Counter

With the edge of the carpet flush along the Cutting Track, you are now ready for the counting and roll up process to begin. In most Reverse Rolling cases, It is probably not necessary to program the Counter. Just be sure to reset the Top Row (Row 1) to "0" before you begin counting and that will record what is actually being measured. Should you wish to program in a desired length, just follow the same steps previously outlined in the "Programming the Electronic Counter" section.

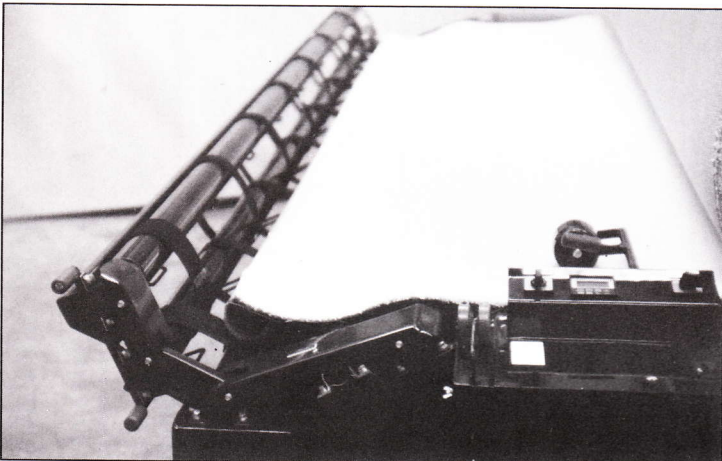

### Starting the Reverse Roll Process

This process requires the use of a cardboard core, no wider than 4" in diameter. Prior to guiding the flooring across onto the Left Side Cradle, place the core into position in the Left Side Cradle. Advance the carpet across and stop it so it is draped half way over the core.

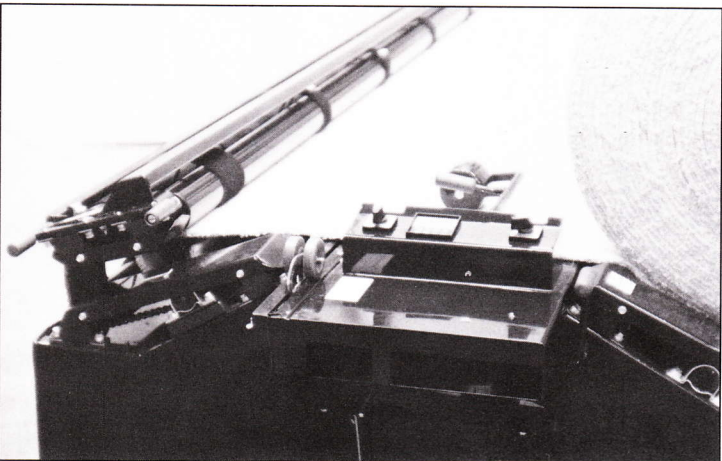

### Securing the Carpet Around the Core

Curl the Left Side Cradle up so it pinches the carpet against the core and it almost fully encloses itself around the core. Lift up on the Left Side Cradle Pressure Handle for better leverage and hold the Cradle in place. Shift the Right Side Clutch Handle to the UP position so as to lock off the Right Side Cradle and turn the Rollers Switch to REVERSE. Continue to apply pressure to the core with the Pressure Handle and at the same time, tap the Foot Cable so as to start the carpet around the core. Stop tapping the Foot Cable once you see the edge of the carpet coming around on its first full turn on the core.

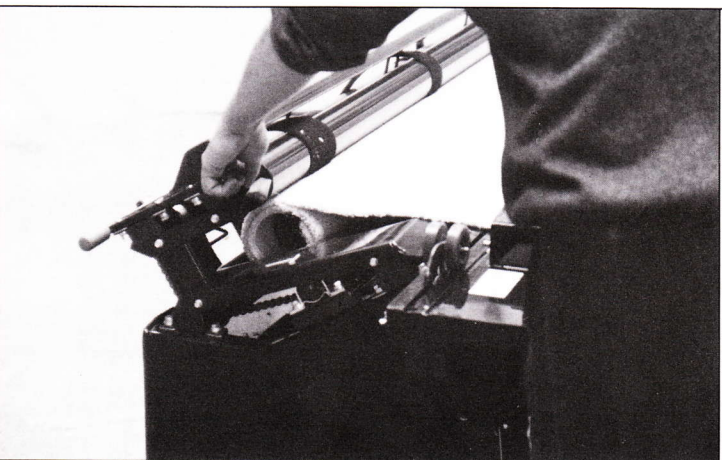

### Continuing the Roll Up Process

Once you have the carpet started around the core, do not release the pressure applied by the Pressure Handle. Next, shift the Reverse Roll Clutch into REVERSE and reengage the Right Side Rollers by shifting the Right Side Clutch Handle back to the DOWN position. Now, tap the Foot Cable so as to continue the roll up for another full turn or two and stop.



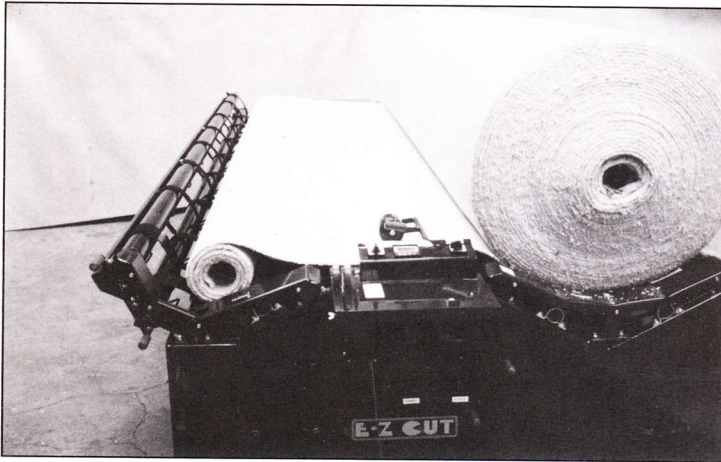

### Continuing the Roll Up Process

At this point, you will probably notice that the core will feel like it is trying to pop out of the cradle. You now want to release the pressure you have applied on the Cradle so it unfolds back to its original position. Depress the Foot Cable again and allow the carpet to continue to roll up around the core letting the machine do the work.

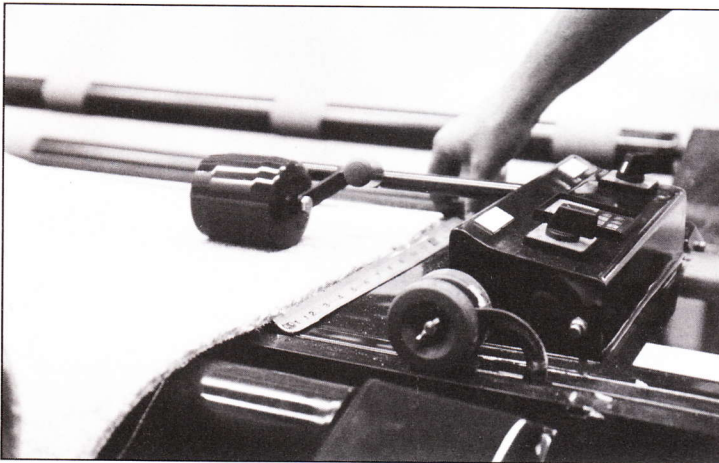

### Measuring the “Tail End” of the Carpet

Remember, when measuring a full or partial roll, you have to take into account the last section or “tail end” of carpet that doesn’t get measured by the Counter after it passes over the Counting Wheel. Follow the same procedure as mentioned before in the “Measuring Full/Partial Rolls” section (i.e. measure the amount that has not passed over the Counting Wheel and add it to the amount on the Top Row of the Counter’s screen. Use the Conversion Table.

NOTE: Once your Reverse Rolling tasks are completed, return all the switches and clutches to their original positions so as not to cause any confusion or grief on your next job.

## SUMMARY

Once again, take your time and experiment with the machine until you feel comfortable operating it. Don’t expect to be an expert after just one or two tries as it takes a little practice and patience before you get the “hang” of it.

**BEFORE YOU ATTEMPT TO MAKE ANY CUTS OR CORRECT MEASURE ANY ROLLS, YOU SHOULD FIRST FOLLOW THE INSTRUCTIONS IN THE NEXT SECTION UNDER “IMPORTANT TIPS”.**

# IMPORTANT TIPS

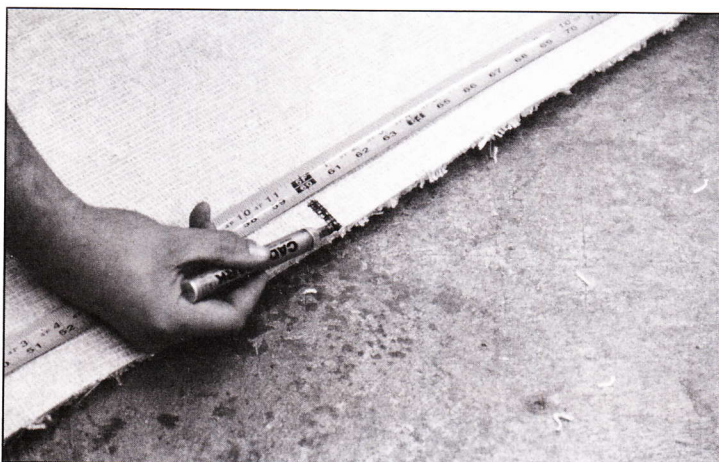

## Testing the Counter's Calibration

Before you make any cuts or attempt to correct measure any rolls, you must ensure the Counter's calibration has not been damaged or changed in freight. To do this, roll out a piece of carpet approximately 25 feet long onto the floor, square it off, and correct measure it with your measuring tape. Using a felt marker or a pen, make a mark on the carpet's backing every 5 feet. Roll up the carpet straight and load it onto the machine's Right Side with the carpet edge coming from the bottom and the markings at the front end of the machine.

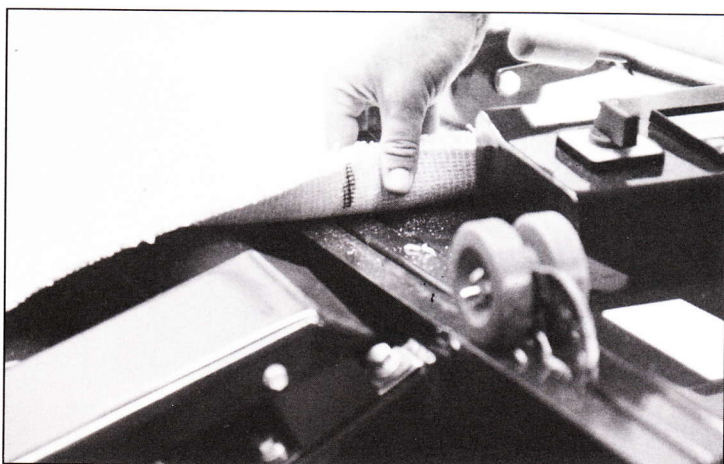

## Continuing the Test

Bring the edge of the carpet up to and flush with the Cutting Track, reset the Counter to zero ("0"), and lower the Counter Weight onto the carpet. Run the carpet through and stop it once it reads "5.00" feet on the Counter Screen. Flip the side of the carpet edge over and your marking should be in line with the Cutting Track. Continue on for another 5 feet and check for the marking again. Continue on for the rest of the roll and then repeat this procedure at least 3 times so as to confirm the test's consistency. As well, you should perform this test on different types of carpet as you will get a slight variance in measurements from one thickness of carpet to another.

**NOTE:** BEFORE RUNNING THESE TESTS PROPERLY, YOU MUST BE FAMILIAR WITH THE MACHINE AND ITS OVERALL OPERATION FIRST. FOR BEST RESULTS, PRACTICE WITH SOME SMALLER ROLLS UNTIL YOU BECOME COMFORTABLE AND CONFIDENT IN USING IT (A COUPLE OF UNINTERRUPTED HOURS IS HIGHLY RECOMMENDED). IF THE TESTS INDICATE A POSSIBLE PROBLEM WITH THE COUNTER'S CALIBRATION, CONTACT AN E-Z CUT REPRESENTATIVE IMMEDIATELY.

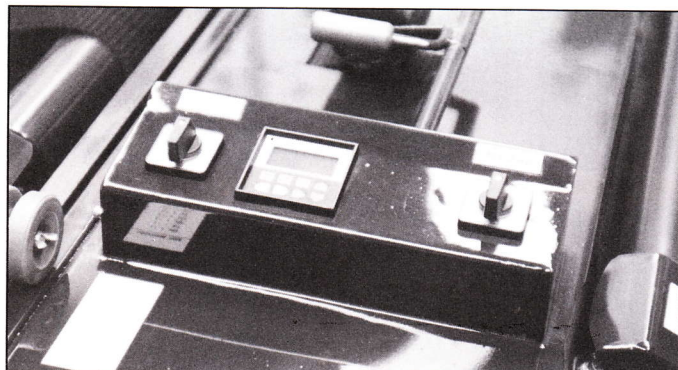

## Adjusting the Counter's Calibration/Scale

This procedure should not be done without the assistance of an E-Z Cut representative:

- 1) Simultaneously, press the small Scaler Reset Button on the Left Side of the Control Panel and the "RUN PGM" button. Then press the "ENT" button.

- 2) The screen will read "Program Scalers". Press the "SEL" button and the screen will read "C Scaler". Press the "SEL" button and the far left digit will begin to flash.
- 3) Press the "SEL" button until you reach the desired digit position to change. Press the "+/-" button to reach the desired value at each position. Press the "SEL" button to move to the next digit position.
- 4) When each desired value is reached, press the "ENT" button, then press the "EXIT" button, then press the "RUN PGM" button, then press the "RST CLR" button.

**NOTE:** Decreasing the value of the "C Scaler" by 0.1 will result in adding approximately 1/2" of carpet for every 20 Feet. Likewise, increasing the "C Scaler" by 0.1 will result in subtracting approximately 1/2" of carpet for every 20 Feet.

# MAINTENANCE TIPS

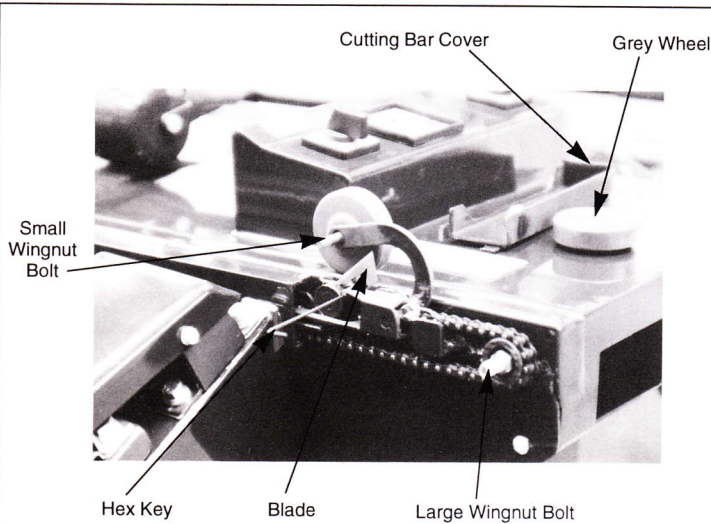

## Changing the Blade

To replace a dull blade, take off the large wingnut and remove the Cutting Bar Cover. Take off the small wingnut on the Cutting Bar Wheel and remove the grey wheel. Insert the key provided and gently loosen off the hex screw. Remove or reverse the blade. Retighten the hex screw gently so as not to strip the screw. Replace and secure the grey wheel and the Cutting Bar Cover.

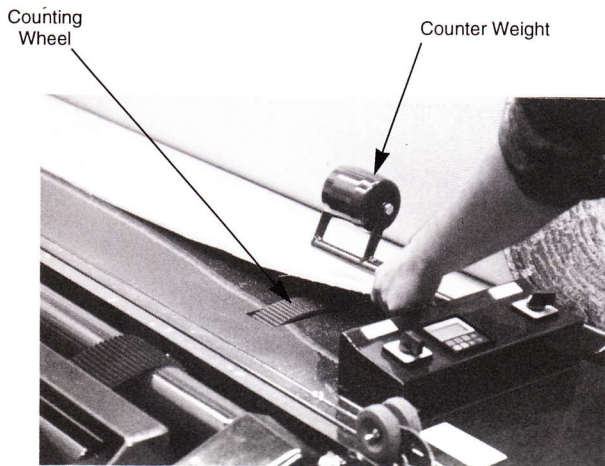

## Counting Wheel and Counter Weight

The 12" Counting Wheel does the actual counting while the Counter Weight presses the flooring up against the Counting Wheel to ensure an accurate measurement. Be careful when loading and unloading rolls so as not to bang or damage these two integral parts. If damaged or dislodged, they can result in inaccurate measurements.

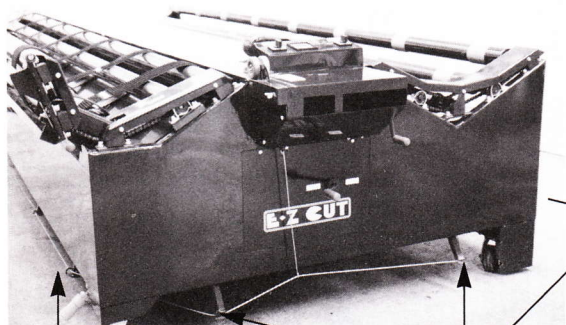

## Lubricating the Foot Cable

Using the thick grease provided, or any thick lubricant for that matter, keep the Foot Cable well lubricated where it passes through the Foot Cable Hooks in the front of the machine. Failure to keep these areas well lubricated will cause them to wear, fray, and eventually break.

Key Areas to Lubricate

## Keep the Cutting Track Clean

Dust and fibers will build up in the Cutting Track and can cause damage if not cleaned on a regular basis. Daily cleaning is recommended by either vacuuming or blowing out the Cutting Track so it remains clear of any build up. AT NO TIME DO YOU WANT TO GREASE THE CUTTING BLADE'S CHAIN AS THAT ONLY ATTRACTS MORE DUST AND FIBERS, THUS INCREASING THE RISK OF DAMAGE.

## Roller Chains

The chains that run the rollers and cutting blade are lubricated at the time of assembly at our plant. These chains and sprockets are designed to work without regular greasing. If they appear dry and shiny, please contact us for further instruction.

## Gearbox

Your gearbox contains regular 80W-90 gear oil which does not have to be changed for a period of 3 to 5 years, depending on the amount of use.

## Clutches

The Reverse Roll and Right Side Cradle Clutches should be lubricated with the same thick grease for the Foot Cables. Apply the grease to the Roll Pin area as well as the Shifting Fork when they become dry or stiff when shifting.

# TROUBLESHOOTING

## PROBLEM

## SOLUTION

### 1. Machine will not run?

- Check the extension cord.
- Check your electrical panel.
- Push the reset buttons on the motors under the machine.
- Check the tension on the Foot Cable.

### 2. Cutting Blade is not running smoothly across the track?

- Check Track and Blade for debris build up.
- Change the Cutting Blade.

### 3. Roll of carpet is not rolling up straight?

- Machine maybe on Caster Wheels and moving.
- Too much pressure applied to roll up Cradle on Left Side.
- Main roll may be sitting off center on Right Side.
- Concrete floor may not be level.

# MACHINE PARTS LIST

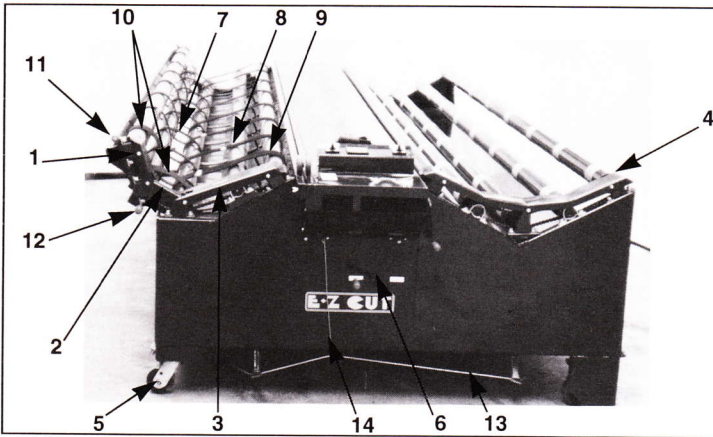

KEY #	PART #	QTY.	DESCRIPTION
1	TC1	1	CHAIN COVER
2	TC2	1	CHAIN COVER
3	TC3	1	CHAIN COVER
4	TC4	1	CHAIN COVER
5	MCW	4	CASTER WHEEL
6	NWR1	1	RUBBER WASHER
7	MR22134C	12	2" x 21 3/4" CPU BELT
8	MR23814	7	2" x 38 1/4" RT BELT
9	MR43814	1	4" x 38 1/4" RT BELT
10	MR42134C	3	4" x 21 3/4" CPU BELT
11	PF13	1	ROLL UP HANDLE
12	PF14	1	PRESSURE HANDLE
13	EFB18	1	FOOT CABLE
14	MH185	1	CABLE HOOK EXTENSION

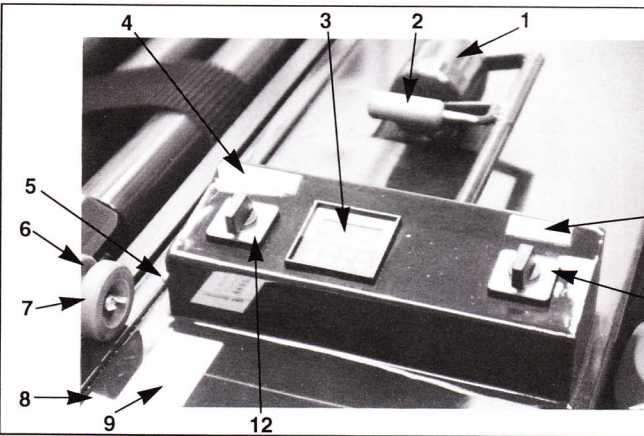

KEY #	PART #	QTY.	DESCRIPTION
1	CWW	1	COUNTER WEIGHT
2	PF13	1	COUNTER WEIGHT HANDLE
3	CED1	1	DURANT COUNTER SCREEN
4	MD6	1	CUTTING BAR SIGN
5	ESM	1	COUNTER SCALER BUTTON
6	DMBH	1	BLADE HOLDER
7	PFHW	1	BLADE HOLDER WHEEL
8	XL332	1	3/32" HEX KEY
9	MD12	1	CONVERSION TABLE
10	ESFR-4	1	ROLLERS SWITCH
11	MD5	1	ROLLERS SIGN
12	ESFR-3	1	CUTTING BAR SWITCH

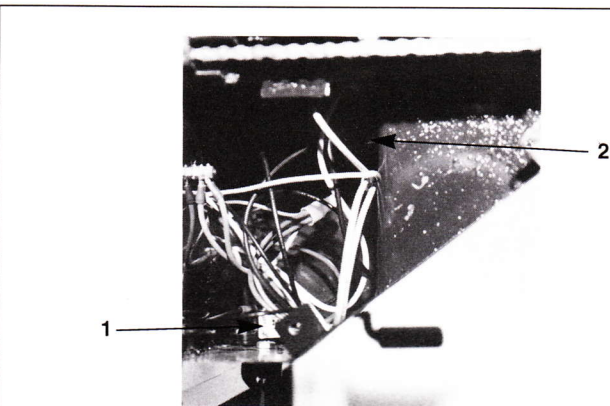

KEY #	PART #	QTY.	DESCRIPTION
1	ESM	1	MICRO SWITCH
2	ER1	1	RELAY

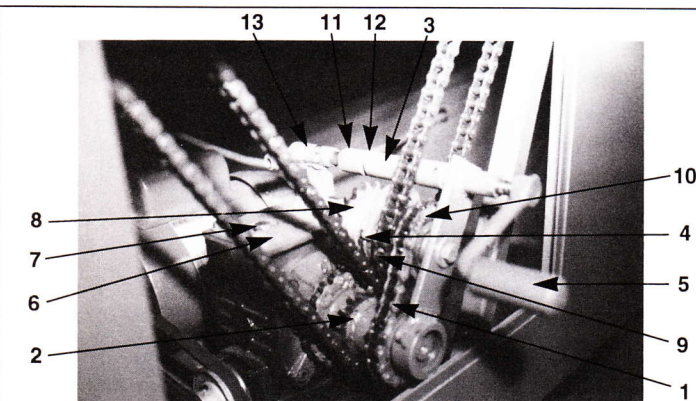

KEY #	PART #	QTY.	DESCRIPTION
1	DGP40	1	REROLLER CHAIN
2	DGP1	1	REROLL DRIVE ASSEMBLY
3	DGP11	1	REROLL SHIFTER FORK
4	DGP12	1	REROLL SHIFT COLLAR
5	DGP13	1	REROLL HANDLE
6	DGR60R	1	REROLL GEARBOX
7	DGP14	1	REROLL PLUG
8	DGPS1	1	INSIDE SPROCKET
9	DGPS2	1	MIDDLE SPROCKET
10	DGPS3	1	OUTSIDE SPROCKET
11	DGP15	2	SHIFTER FORK COLLAR
12	DGP16	2	FORK SPRINGS
13	NR14-58	1	1/4" x 5/8" ROLL PIN

# MACHINE PARTS LIST

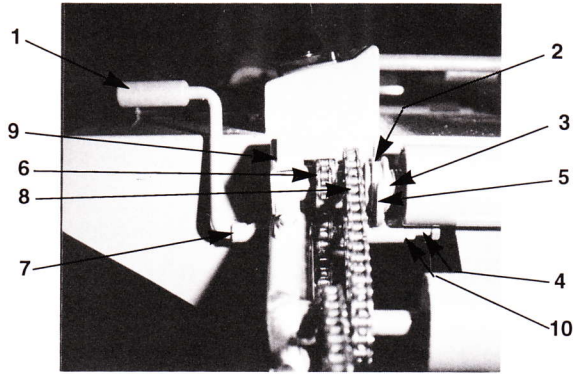

KEY #	PART #	QTY.	DESCRIPTION
1	TLCH	1	RIGHT CLUTCH HANDLE
2	TLSC	1	RIGHT CLUTCH SHIFTING COLLAR
3	TLSP	1	RIGHT CLUTCH SPRING
4	NB12-112	1	RIGHT CLUTCH ADJUSTING BOLT (1/2" x 1 1/2")
5	TLF	1	RIGHT CLUTCH SHIFTING FORK
6	TLS2	1	CLUTCH DRIVE SPROCKET
7	TLS	1	SPIRAL
8	TLS1	1	ROLLER DRIVE SPROCKET
9	B204-12	1	BEARING
10	N12	1	1/2" LOCK NUT

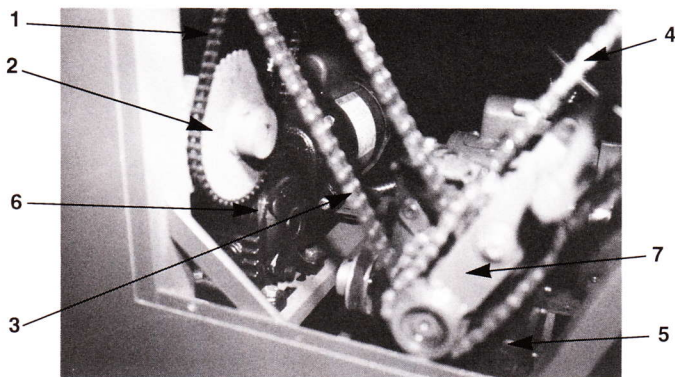

KEY #	PART #	QTY.	DESCRIPTION
1	DC35	1	CUTTING BAR CHAIN
2	S35W45	1	SPROCKET
3	DC405	1	DRIVE CHAIN
4	DC406	1	DRIVE CHAIN
5	DGR60	1	GEARBOX
6	DGF50	1	FLANGE GEARBOX
7	DGR60R	1	REROLL UNIT

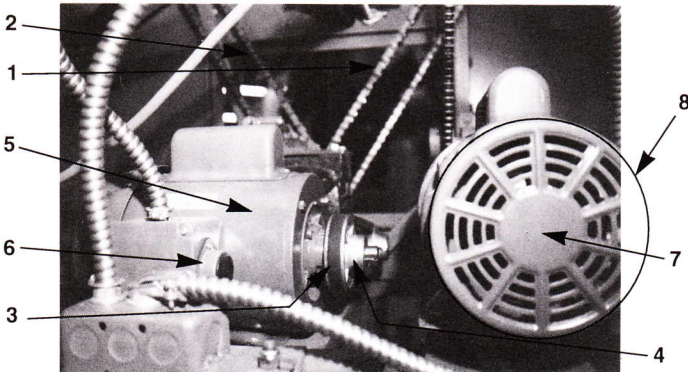

KEY #	PART #	QTY.	DESCRIPTION
1	DC406	1	DRIVE CHAIN
2	DC405	1	DRIVE CHAIN
3	DBA23	2	A23 BELT
4	DPAA583	1	5/8" x 3" A PULLEY
5	EM34	1	3/4 HP MOTOR
6	EMR34	1	3/4 HP RESET BUTTON
7	EM13	1	1/3 HP MOTOR
8	EMR13	1	1/3 HP RESET BUTTON

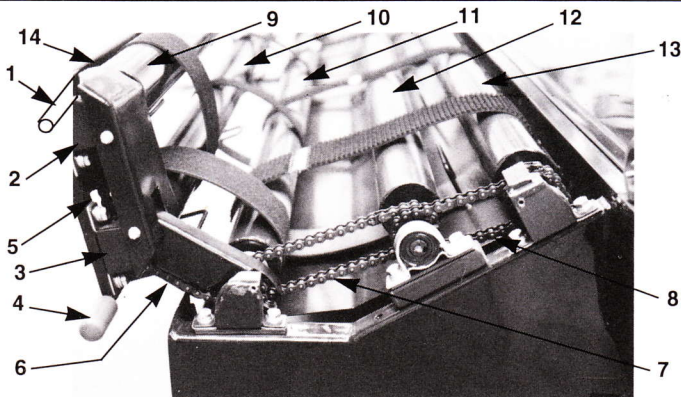

KEY #	PART #	QTY.	DESCRIPTION
1	PF13	1	ROLL UP HANDLE
2	BS204-2	2	PILLOWBLOCK & CHAIN
3	BS204-1	3	GUARD BRACKET
4	PF14	1	PILLOWBLOCK & CHAIN
5	DC401	1	GUARD BRACKET
6	DC402	1	PRESSURE HANDLE
7	DC403	1	CHAIN
8	DC404	1	CHAIN
9	TRO1	1	CHAIN
10	TRO2	1	LEFT ROLLER #1
11	TRO3	1	LEFT ROLLER #2
12	TRO4	1	LEFT ROLLER #3
13	TRO5	1	LEFT ROLLER #4
14	TB1	1	LEFT ROLLER #5
			ROLLER HOLDER & BELT GUIDE

# MACHINE PARTS LIST

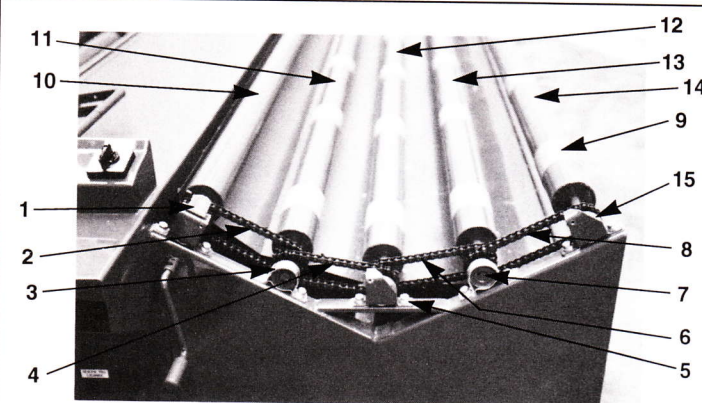

KEY #	PART #	QTY.	DESCRIPTION
1	BS204-3	2	PILLOWBLOCK & CHAIN GUARD BRACKET
2	DC407	1	CHAIN
3	BS204	17	PILLOWBLOCK
4	DC408	1	CHAIN
5	NB38-1	40	3/8" x 1" BOLT
6	DC409	1	CHAIN
7	B204-12	24	204-12 BEARING
8	DC410	1	CHAIN
9	MS	32	SAFETY WALK
10	TRO6	1	RIGHT ROLLER #6
11	TROT	1	RIGHT ROLLER #7
12	TRO8	1	RIGHT ROLLER #8
13	TRO9	1	RIGHT ROLLER #9
14	TR10	1	RIGHT ROLLER #10
15	BS204-1	3	PILLOWBLOCK & CHAIN GUARD BRACKET

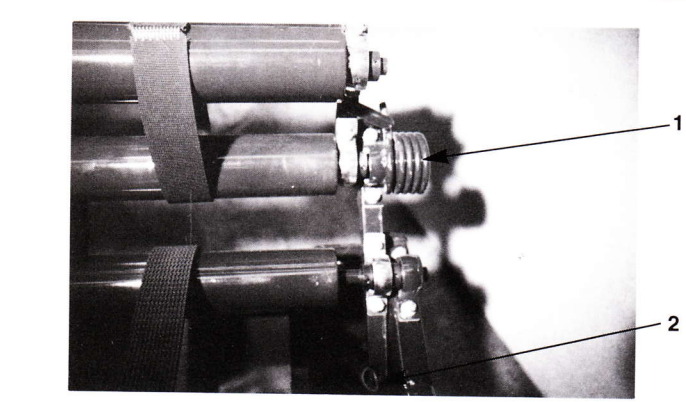

KEY #	PART #	QTY.	DESCRIPTION
1	TS5	1	FOLD UP SPRING
2	TSE14	1	EXTENSION SPRING

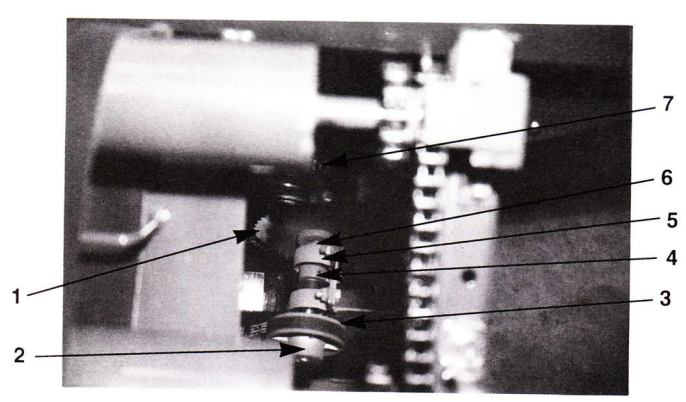

KEY #	PART #	QTY.	DESCRIPTION
1	S35W45	1	35W45 SPROCKET
2	DPA1-L4J	1	5/8" x 4 1/2" PULLEY
3	DBA23	1	A23 BELT
4	TMCS	1	CUTTING BAR SHAFT
5	B202-10	1	5/8" BEARING
6	BS202	1	5/8" PILLOWBLOCK
7	DC35	1	CUTTING BAR CHAIN

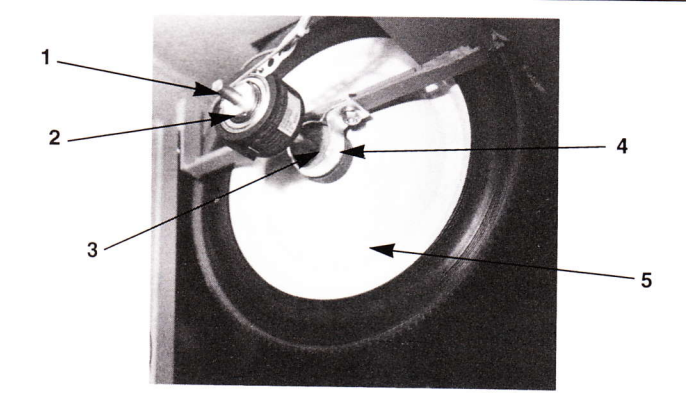

(View from under Table)

KEY #	PART #	QTY.	DESCRIPTION
1	CS	1	COUNTER SHAFT
2	CEE	1	COUNTER ENCODER
3	BCS	1	COUNTER SHAFT BEARING
4	BS202	1	PILLOWBLOCK
5	CW12	1	COUNTING WHEEL



## E-Z CUT WARRANTY

E-Z CUT Inc. warrants our products to be free from defects in materials and workmanship for a period of one (1) year. The E-Z CUT carpet and vinyl cutting systems were designed and manufactured with serviceability and ease of maintenance in mind. In the event that you require assistance or any service work, please contact our office prior to proceeding with any warranty repairs.

*For Further Information, Contact:*

**E-Z CUT INC.**

433 St. Mary's Rd.  
Winnipeg, Manitoba  
Canada R2M 3K7

PH. (204) 235-1122 FAX (204) 237-9339  
U.S. Toll Free 1-800-661-5156